



东莞市凡睿电子科技有限公司

DONG GUAN FAN RUI ELECTRONICS&TECHNOLOGY CO.,LTD.

TEL: (0769) 81805438/86866001 13751429385 FAX (0769) 82991458 E-mail: fanrui@dgfarui.com

网址: <http://www.dgfarui.com>

地址: 东莞市茶山镇京山第三工业区

旋转式电位器规格书 Rotary potentiometer specification	核 准 Approved	审 核 Q.I.Department	经办者 Design Dept.
	刘建国	莫勤	王芳
适用机种: RK097 双联系列 Applicable Models : RK097 Single Unit With Switch Series			

Electrical Characteristics 电气特性

total resistance 全阻抗值	50 K Ω ;
Total Resistance Tolerance 全阻抗容许误差值	<input type="checkbox"/> $\pm 10\%$ <input type="checkbox"/> $\pm 15\%$ <input checked="" type="checkbox"/> $\pm 20\%$ <input type="checkbox"/> $\pm 30\%$ <input type="checkbox"/> _____
Resistance Taper 阻抗特性型式	<input type="checkbox"/> A 、 <input checked="" type="checkbox"/> B 、 <input type="checkbox"/> C 、 <input type="checkbox"/> D
Rated Power 负载功率	Linear Taper B: 0.05 w Other Tapers : 0.025w (Other Tapers : A, C, D)
Maximum operating voltage 最高使用电压	AC 50V DC 10V
Sliding Noise 噪声	Less than 100 mv
Insulation Resistance 绝缘阻抗值	More than 100 M Ω at DC 250 V
Withstand Voltage 耐电压特性	1 minute at AC 100 V
Residual Resistance 残留阻抗值	Term. 1~2 :Less than 20 Ω
	Term. 2~3 :Less than 20 Ω
Gang Error (Dual Unit) 同步误差值	- 40 dB ~ 0 dB ± 3 dB

Mechanical Characteristics 机械特性

Total Rotation Angle 全回转角度	300° $\pm 5^\circ$
Rotation Torque 旋转力矩	30 ~ 250 gf.cm
Rotation Stopper Strength 旋转止动强度	4.0 Kgf.cm Min.
Push-Pull Strength 轴柄推拉承受强度	Pull: 5.0 Kg.f Min. Push: 5.0 Kg.f Min
Resistance to soldering heat 焊锡耐热性	Manual Soldering: Less than 300°C and quicker than 3 seconds. 手焊: 300 $\pm 10^\circ\text{C}$ 以下, 3 秒以内
Durability Rotational Life 耐久次数值	15,000 Cycles Min.



东莞市凡睿电子科技有限公司

DONG GUAN FAN RUI ELECTRONICS&TECHNOLOGY CO.,LTD.

TEL: (0769)81805438/86866001 13751429385 FAX (0769)82991458 E-mail: fanrui@dgfarui.com

网址: http://www.dgfarui.com

地址: 东莞市茶山镇京山第三工业区

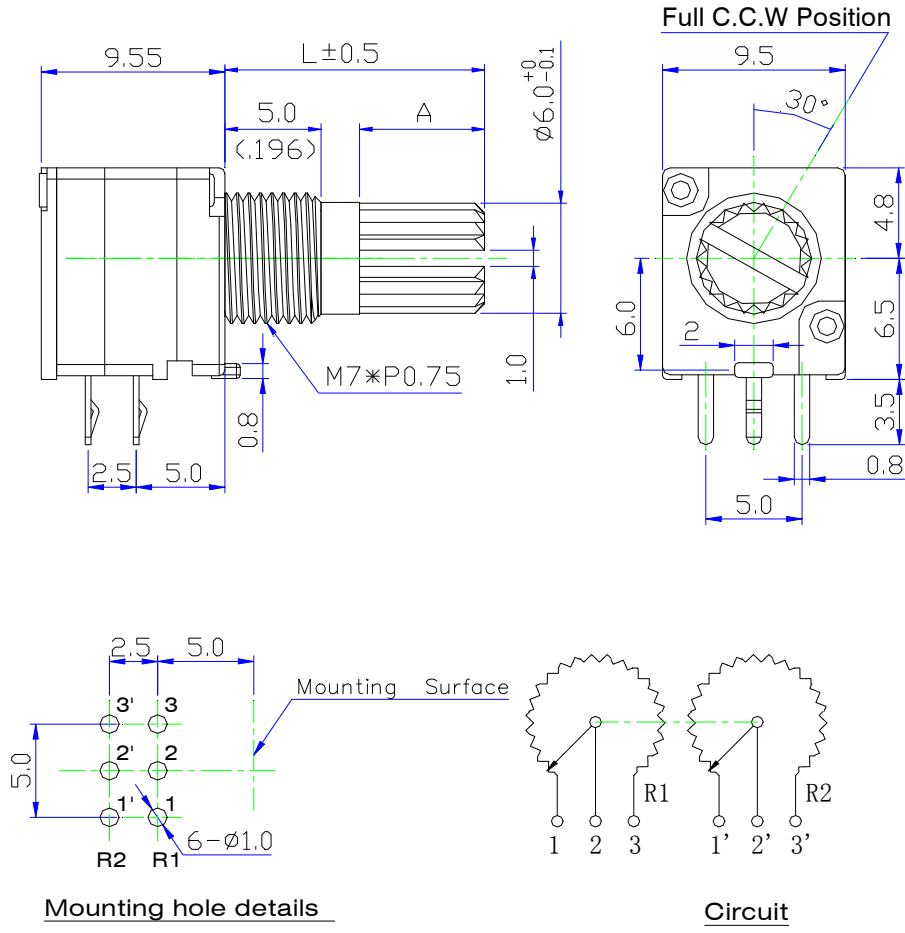

L	10	12	13	15	20	25	30
A	4	4	6.5	8.5	13.5	18.5	23.5

东莞市凡睿电子科技有限公司 DONG GUAN FAN RUI ELECTRONICS&TECHNOLOGY CO.,LTD.				③			
				②			
				①			
Title	RK097 Series			Devision	Date	Design	
Dwg Name	RK097GH01-M7B5-YB			Unit	Scale	TOLERANCE	
Dwg No	CPT-097-033	Version	A	MM	3:1	UNDER 10	±0.3
DESIGN	CHECK	APPROVAL	MTL			10 ~ 100	±0.5
			SPEC			OVER 100	±0.8
			DISPOSAL			ANGULAR DIMENSION	±5°



东莞市凡睿电子科技有限公司

DONG GUAN FAN RUI ELECTRONICS&TECHNOLOGY CO.,LTD.

TEL: (0769)81805438/86866001 13751429385 FAX (0769)82991458 E-mail:fanrui@dgfarui.com

网址: http://www.dgfarui.com

地址: 东莞市茶山镇京山第三工业区

电位器曲线图

TAPERS B SERIES

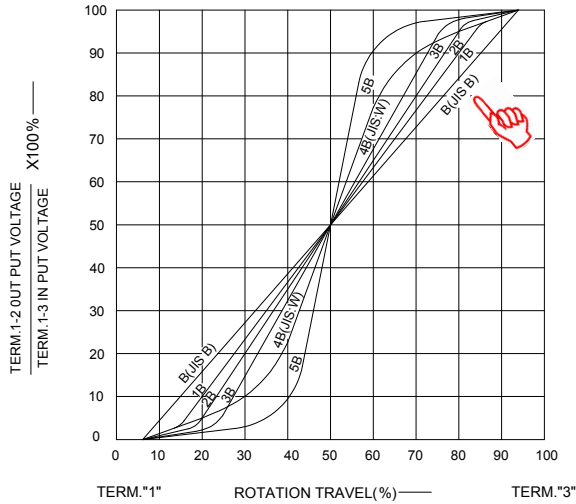

TAPERS B WITH 50% TAP

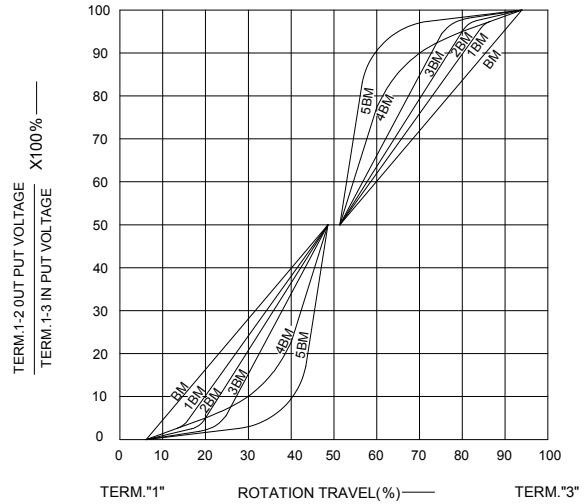

TAPERS A SERIES

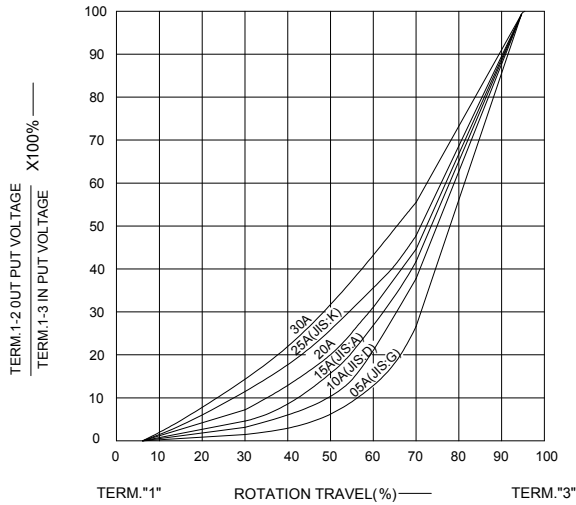

TAPERS A & C WITH 50% TAP

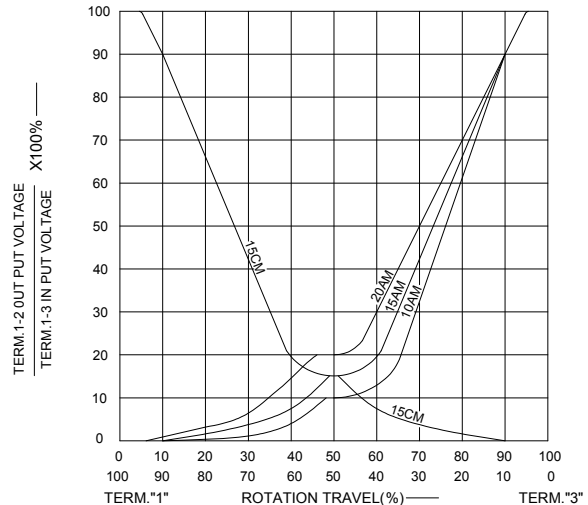

TAPERS C SERIES

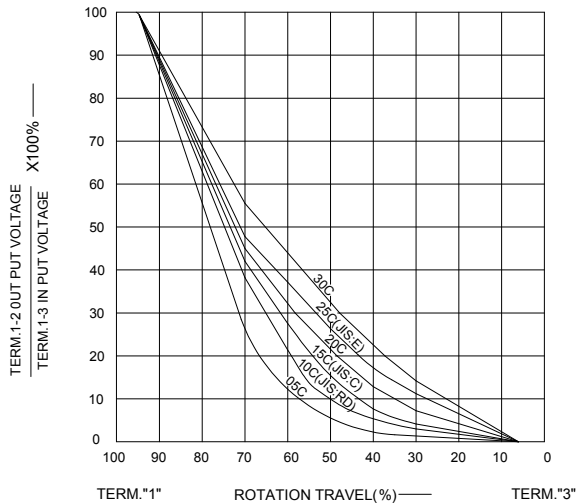

TAPERS M & N

